



**ECO
LIGHT**
INDUSTRIAL LED

**LED
INDUSTRIAL
FLOOD
LIGHTS**

LEDIFL32-300AC • LEDIFL33-300AC

300W LED INDUSTRIAL FLOODLIGHTS

This 300 watt LED floodlight range is one of the most powerful in the ECOlight range. It provides an exceptionally well lit working environment for those working under it.

These units are perfect for sports fields, ports, airports, carparks, and trucking yards where good lighting is required over a larger scale.

The adjustable bracket means the angle of the light fitting can be easily adjusted to suit lighting requirements.

The lens design enables the LEDIFL32 & LEDIFL33 to be directed into specific areas very effectively.



TECHNICAL SPECIFICATIONS

Fixture/Part No.	LEDIFL32-300AC	LEDIFL33-300AC
Input Voltage	AC90~305V	
Frequency Range	50~60Hz	
Power Consumption	300W	
LED	CREE XP-L	
LED Beam Angle	45°	60°
Operating Temperature	-20°C ~ 45°C	
Storage Temperature	-40°C ~ 70°C	
Weight	11 kg	
Lifespan	About 50,000 Hours (@25°C)	
Housing	AL	
Waterproof Rating	IP67	
Color Temperature	5000K	
Color Rendering(Ra)	75% or above	
Luminous Flux	37,800 lm	
Light Efficiency	126 lm/W	
Dimensions	520x325x206mm	



78 Cryers Road
East Tamaki
Auckland.
NEW ZEALAND
phone: 64 9 272 5619

 **ECO
LIGHT**
www.ecolight.co.nz

PRODUCT IMAGES

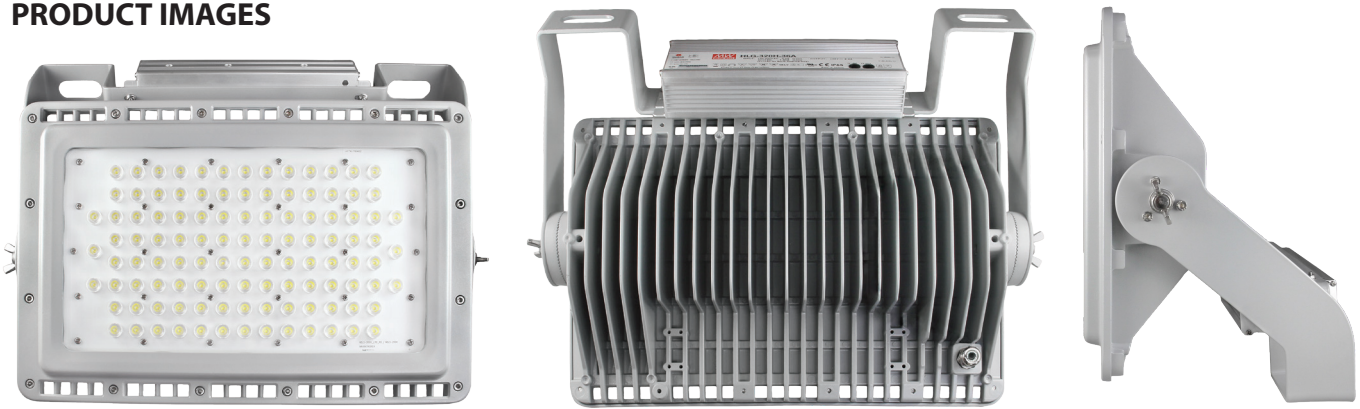

DIMENSIONS

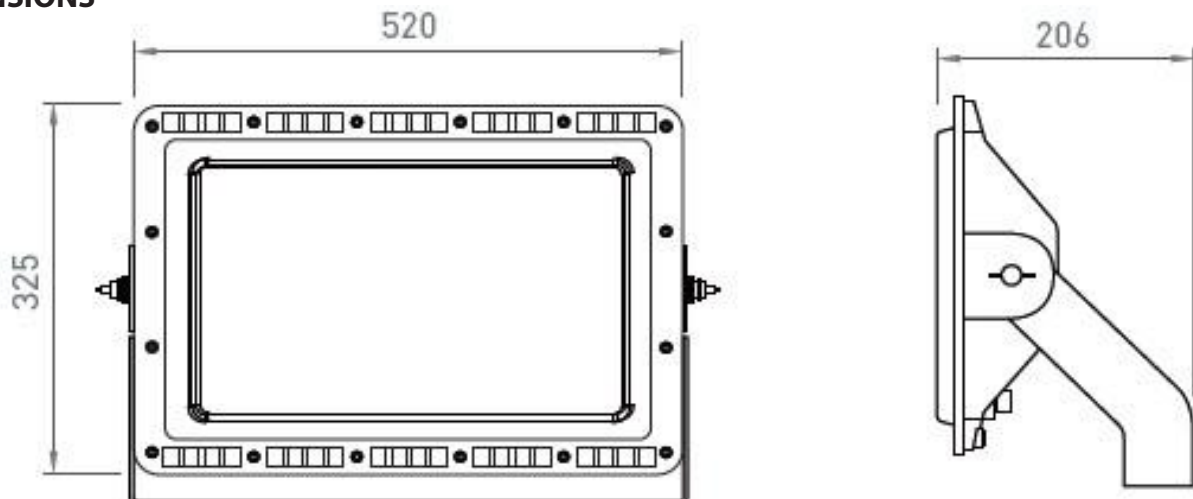

CONE DATA & PHOTOMETRICS DATA

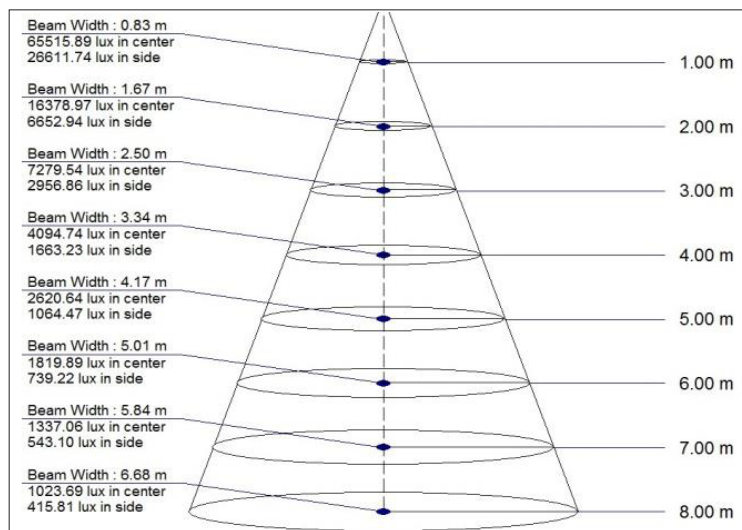
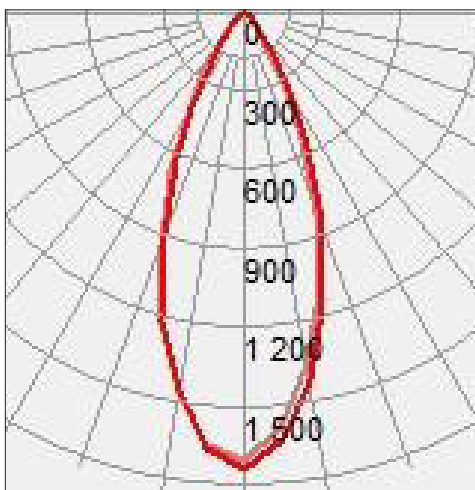

78 Cryers Road
East Tamaki
Auckland.
NEW ZEALAND
phone: 64 9 272 5619